

### Evaluation for Piston, Piston Ring ↔ Cylinder Bore Sticking, Tribological and Friction Characteristics

- 1 Making the Test Piece Behave in the Condition of Equivalent to Actual Situation
- 2 Piston Friction Measurement by Floating Liner
- 3 Waveform Processing and Analyzing Every Crank Angle
- 4 Oil Film Visualization and Thickness Measurement by High Speed Camera (Option)

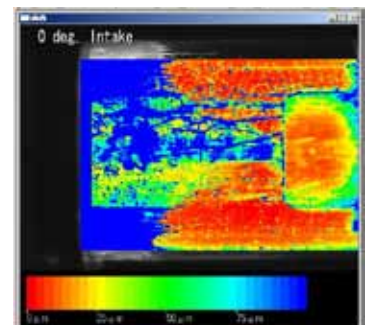
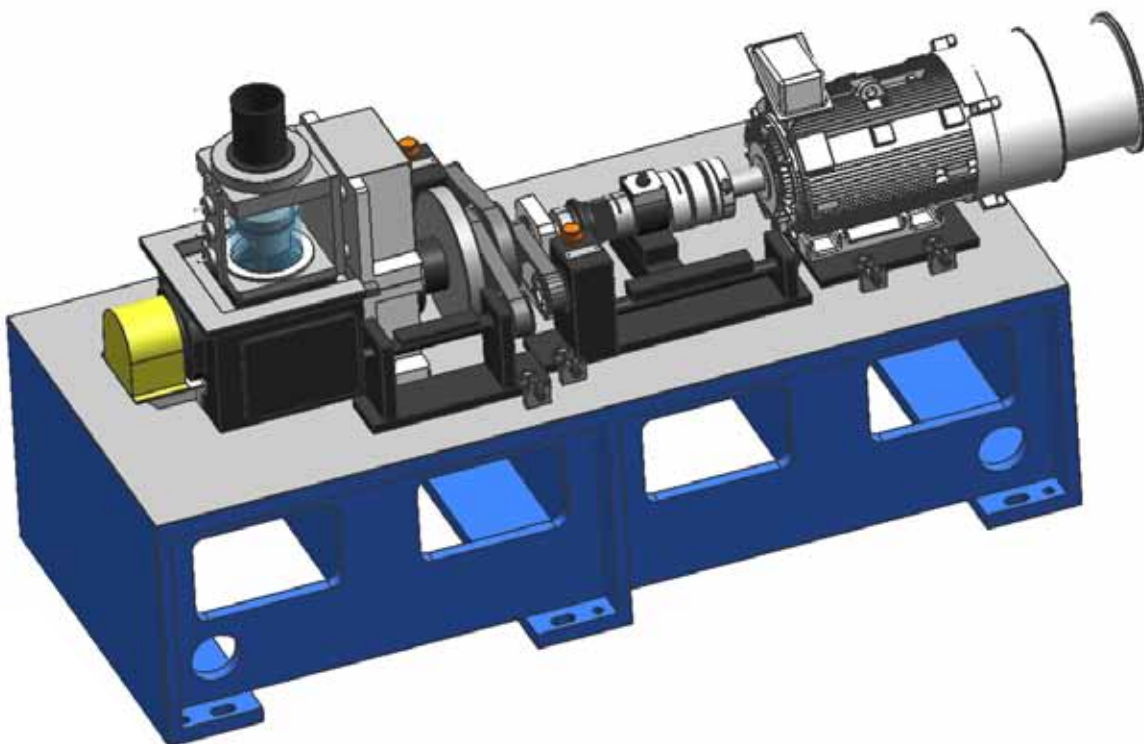

		Standard	Option
Test Piece	Piston	$\phi 73$ to $\phi 87$	Consultation
Reciprocating Motion Unit	Driving Motor	7.5kW	Consultation
	Revolutions	10 to 2,000rpm	Consultation
Environment	Oil Temperature	Room Temp. to 100°C	Consultation
	Oil Flow	to 1.5L/min	Consultation
	Liner Heating	Room Temp. to 100°C	Consultation
Measurement	Frictional Force	to 5kN	Consultation
	Piston Side Pressure	to 5kN	Consultation
	Crank Angle	0 to 360deg	Consultation
	Revolutions	10 to 2,000rpm	Consultation
	Torque	to 50N·m	Consultation
	Vibration		X Axis / Y Axis
Camera	Oil Film Thickness		Quartz Glass Liner, Camera, Lighting, Analysis Software
Size (mm)/ Weight (kg)		W1,600×D600×H1,200mm / 750kg (Test System)	
Power Supply, Capacity		AC 200V 3-phase (50/60Hz), 20kVA	

## Component Layout

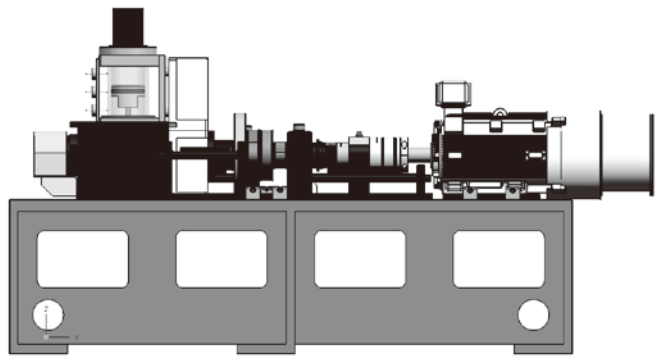
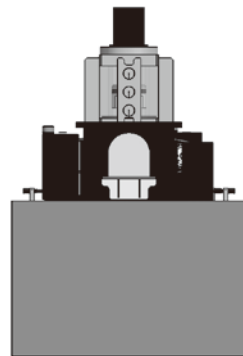
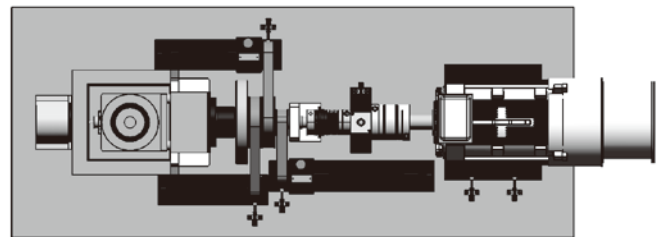
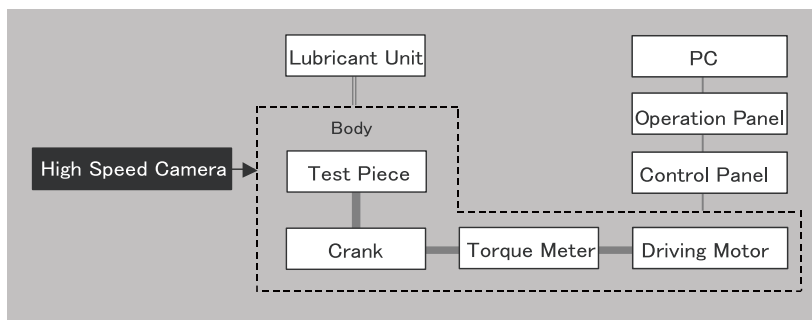

**Space  
creation**

Space Creation Co.,Ltd.

1341-1 Zora-cho, Minami-ku, Hamamatsu-shi,  
Shizuoka-ken, 432-8062, Japan  
TEL : +81-53-447-2755 FAX : +81-53-447-2833  
E-mail : general@spacecreation.co.jp  
URL : <http://www.spacecreation.co.jp>

Agency

		Standard	Option
Test Piece	Piston	$\phi 73$ to $\phi 87$	Consultation
Reciprocating Motion Unit	Driving Motor	7.5kW	Consultation
	Revolutions	10 to 2,000rpm	Consultation
Environment	Oil Temperature	Room Temp. to 100°C	Consultation
	Oil Flow	to 1.5L/min	Consultation
	Liner Heating	Room Temp. to 100°C	Consultation
Measurement	Frictional Force	to 5kN	Consultation
	Piston Side Pressure	to 5kN	Consultation
	Crank Angle	0 to 360deg	Consultation
	Revolutions	10 to 2,000rpm	Consultation
	Torque	to 50N·m	Consultation
	Vibration		X Axis / Y Axis
Camera	Oil Film Thickness		Quartz Glass Liner, Camera, Lighting, Analysis Software
Size (mm)/ Weight (kg)		W1,600×D600×H1,200mm / 750kg (Test System)	
Power Supply, Capacity		AC 200V 3-phase (50/60Hz), 20kVA	

## Component Layout

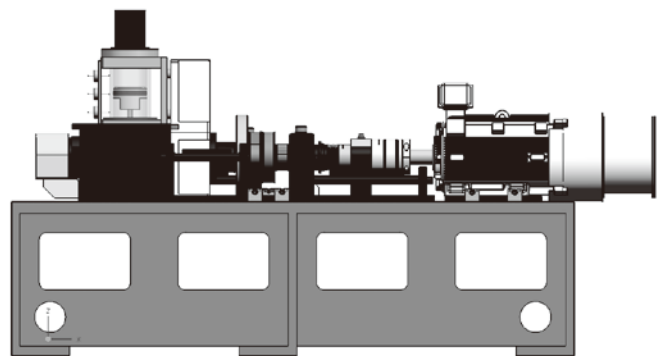
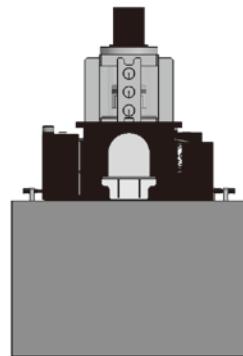
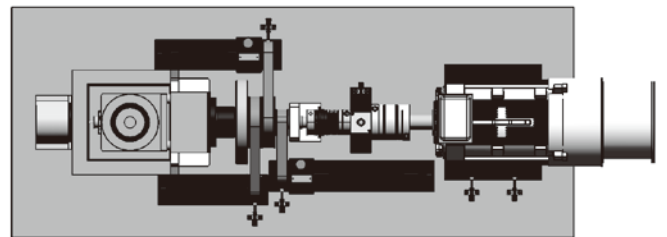
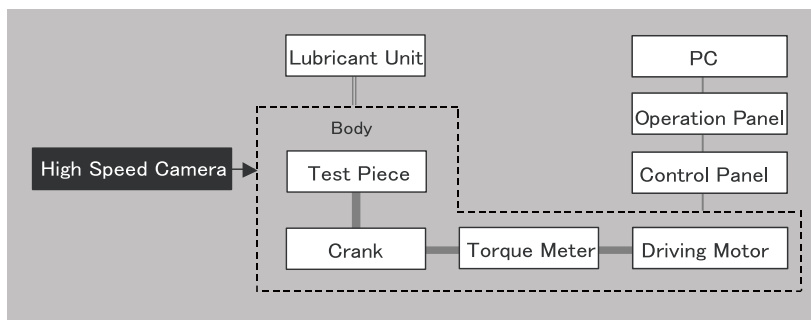

Agency

**Space  
creation**

Space Creation Co.,Ltd.

1341-1 Zora-cho, Minami-ku, Hamamatsu-shi,  
Shizuoka-ken, 432-8062, Japan  
TEL : +81-53-447-2755 FAX : +81-53-447-2833  
E-mail : general@spacecreation.co.jp  
URL : <http://www.spacecreation.co.jp>